



**PART NO. SFI1206SA240-030J**

**1.1 Technology Data**

	Symbol	Value	Unit
Maximum allowable continuous DC voltage	$V_{DC}$	12	V
Breakdown voltage measured	$V_V$	24(±10%)	V
Maximum clamping voltage	$V_{CLAMP}$ <	40	V
Maximum Peak Current	$I_{Peak}$	400 (for +/- 1 time)	A
Jump Start Voltage ( 5min )	$V_{JUMP}$	24.5	V
Load Dump	$W_{LD}$	3 (for 10 times)	J

**1.2 Reference Data**

Typical capacitance value measured at 1K Hz	C	700	pF
Response time	$T_{rise}$ <	1	ns
Non-linear coefficient	$\alpha$ >	20	
Leakage current (Before Surge Test)	$I_V$ <	5	uA
Leakage current (After Surge Test)	$I_{VA}$ <	50	uA
Operation ambient temperature		-55~+125	°C
Storage temperature		-55~+150	°C

**1.3 Other Data**

Body		Nano Special Ceramic	
End termination		Ag/Sn(1206~2220)	
Packaging		Reel	
Complies with Standard		IEC61000-4-5 ISO7637-2	
Complies with RoHs Standard		Yes	
Lead Content	<	1000	ppm
Marking		None	

Notes :

- \* 1 The breakdown voltage was measured at 1 mA current.
- \* 2 The clamping voltage was measured at standard current, 1206(1A).
- \* 3 The Peak Current was tested at 8/20 us waveform.
- \* 4 Load Dump meet ISO7637-2 pulse 5.
- \* 5 The leakage current was tested at working voltage, 12V.
- \* 6 The capacitance value only for customer reference, it's not formal specification.
- \* 7 The components shall be employed within 1 year, in the nitrogen condition.

Part No. :	<b>1206SA240-030J</b>	Document No.	<b>AS-RD1206MA127-LF</b>	REV.	<b>C</b>
------------	-----------------------	--------------	--------------------------	------	----------

### 1.4 Features of SHA Series

1. RoHS compliant
2. SMD type Body size 1206
3. Meet ISO7637-2 pulse 5
4. Qualified based on AEC-Q200
5. Bidirectional and symmetrical V/I characteristics
6. Large withstanding surge current capability : 400A (@8/20)
7. Excellent low leakage current <math><5\mu\text{A}</math>
8. The jump start is 24.5V of 5min
9. Large Load Dump withstanding capability : 3J (10 times)
10. Operating temperature range :  $-55 \sim +125^{\circ}\text{C}$
11. Multi-Layers construction provides higher power dissipation

### Equivalent Circuit

- ☆L Body Inductance
- ☆C Device Capacitance
- ☆VR Voltage Variable Resistor
- ☆R Insulation Resistor
- ☆Diode Voltage clamped
- ☆PTC For low leakage current

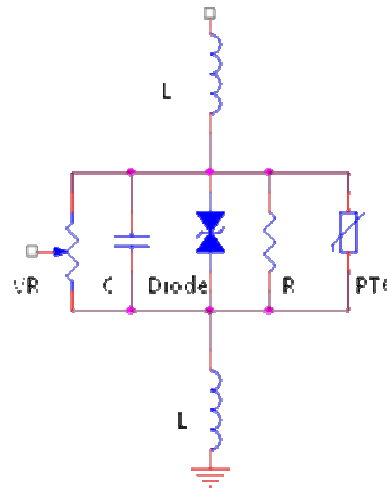

### 2.Size

Model	1206 Series
Length(L)	3.2 ±0.2mm
Width(W)	1.67 ±0.15mm
Thickness(T)	1.70 mm Max
Termination(a)	0.50±0.2mm

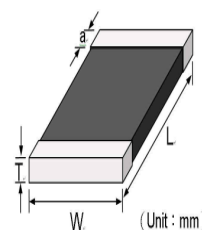

Part No. :	<b>1206SA240-030J</b>	Document No.	<b>AS-RD1206MA127-LF</b>	REV.	<b>C</b>
------------	-----------------------	--------------	--------------------------	------	----------

### 3. Load Dump and Surge Wave Form

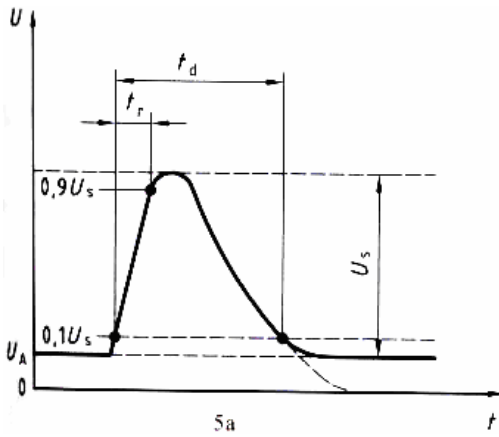

Load Dump Test waveform

#### ISO7637-2:2004 pulse 5a

Parameter	Value
Us	65V to 87V
Ri	0.5 Ω to 4 Ω
td	40ms to 400ms
tr	5ms to 10ms

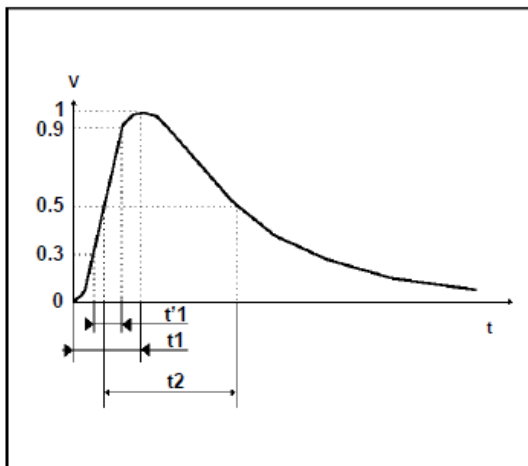

8/20µs waveform current

#### IEC61000-4-5 Standards

SEVERITY LEVEL	t1 (=1.67t'1)	t2
1	8 µs	20 µs

Part No. :	<b>1206SA240-030J</b>	Document No.	<b>AS-RD1206MA127-LF</b>	REV.	<b>C</b>
------------	-----------------------	--------------	--------------------------	------	----------



### 4. Environmental Reliability Test

Test	Standard	Requirement	Specifications
High Temperature Exposure (Storage)	MIL-STD-202 Method 108	Test temp. : 150 ±3°C Duration: 1000 h Unpowered	1.No visible damage 2. $ \Delta V1mA/V1mA  \leq 10\%$  Measurement at 24±2 hours after test conclusion.
Temperature Cycling	JESD22 Method JA-104	Lower test temp. : -40±3°C Upper test temp. : 125±3°C Number of cycles : 1000	
Moisture Resistance	MIL-STD-202 Method 106	Lower test temperature: 25±3°C Upper test temperature: 65±3°C Rel. humidity of air:90%~98% ( during cooling phase:80%~98%) Duration of 1 cycle: 24 h Number of cycles: 10 , Unpowered	
Biased Humidity	MIL-STD-202 Method 103	Test temp. : 85±3°C Rel. humidity of air : 85~90% Duration: 1000 h Bias at Working Voltage Vdc.	
Operational Life	MIL-STD-202 Method 108	Test temp.: 125±3°C Duration: 1000 h Bias at Working Voltage Vdc.	
Mechanical Shock	MIL-STD-202 Method 213	Test Condition F Peak value : 1500g's Half sine Waveform	
Vibration	MIL-STD-202 Method 204	Acceleration : 5 g's Sweep time: 20 min Frequency range: 10 to 2000 Hz 3×12 cycles	
Thermal Shock	MIL-STD-202 Method 107	Lower test temp. : -55±3°C Upper test temp. : 125 ±3°C Dwell time : 15 minutes. Air-Air. Number of cycles : 300	
Electrical Transient Conduction	ISO-7637-1	Test pulses 1 to 5	

Part No. :	<b>1206SA240-030J</b>	Document No.	<b>AS-RD1206MA127-LF</b>	REV.	<b>C</b>
------------	-----------------------	--------------	--------------------------	------	----------

## 5. Soldering Recommendations

### 5.1 Recommended solder pad layout

(Unit : mm)

	A	B	C
1206	1.8~2.5	1.2~1.8	1.5~2.0

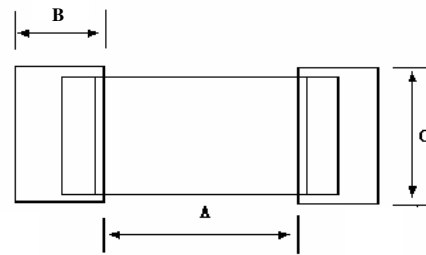

### 5.2 The SIR test of the solder paste shall be done (Based on JIS-Z-3284)

### 5.3 Steel plate and foot distance printing

Foot distance printing (mm)	Steel Plate thickness (mm)
> 0.65mm	0.18mm
0.65mm~0.5mm	0.15mm
0.50mm~0.40mm	0.12mm
<=0.40 mm	0.10mm

### 5.4 The IR reflow and temperature of Soldering for Pb Free

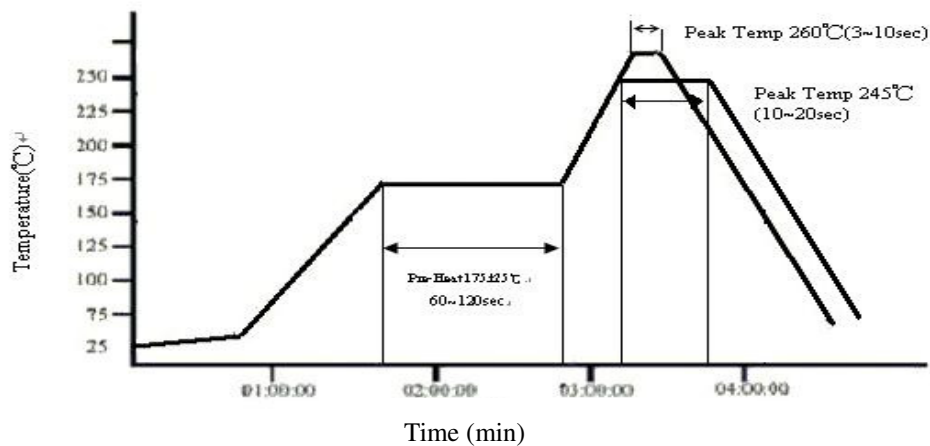

#### ☆ IR reflow Pb Free Process suggestion profile

- (1) The solder recommend is Sn96.5/Ag 3.5 of 120 to 150 μm
- (2) Ramp-up rate (217°C to Peak) + 3°C/second max
- (3) Temp. maintain at 175 +/-25°C 180 seconds max
- (4) Temp. maintain above 217 °C 60-150 seconds
- (5) Peak temperature range 245°C +20°C/ -10 °C time within 5 °C of actually peak temperature 10~20 seconds
- (6) Ramp down rate +6 °C/second max.

Part No. :	<b>1206SA240-030J</b>	Document No.	<b>AS-RD1206MA127-LF</b>	REV.	<b>C</b>
- 6 -					



※Perform adequate test in advance as the reflow temperature profile will vary according to the conditions of the manufacturing process, and the specification of the reflow furnace.

**5.5 Resistance to Soldering Heat-High Temperature Resistance: 260°C, 10sec and 3 times.**

**5.6 Hand Soldering**

In hand soldering of the SHA Devices. Large temperature gradient between preheated the SHA Devices and the tip of soldering iron may cause electrical failures and mechanical damages such as crackings or breakings of the devices. The soldering shall be carefully controlled and carried out so that the temperature gradient is kept minimum with following recommended conditions for hand soldering.

5.6.1 Recommended Soldering Condition 1

- (1) Solder : **0.12~0.18mm** Thread solder (Sn96.5:Ag3.5) with soldering flux in the core. Rosin-based and non-activated flux is recommended.
- (2) Preheating  
The SHA Devices shall be preheated so that Temperature Gradient between the devices and the tip of soldering iron is 150°C or below.
- (3) Soldering Iron  
Rated Power of 20w max with 3mm soldering tip in diameter.  
Temperature of soldering iron tip 380°C max, 3-5sec ( The required amount of solder shall be melted in advance on the soldering tip.)
- (4) Cooling  
After soldering. The SHA Devices shall be cooled gradually at room ambient temperature.

5.6.2 Recommended Soldering Condition 2 ( Without preheating )

- (1) Solder iron tip shall not directly touch to ceramic dielectrics.
- (2) Solder iron tip shall be fully preheated before soldering while soldering iron tip to the external electrode of SHA Devices.

**5.7 Recommended using IR Reflow Process. The Wave Soldering Process and Immersion Tin Process can't to be Adopted for this Product.**

**5.8 Post Soldering Cleaning**

5.8.1 Residues of corrosive soldering fluxes on the PC board after cleaning may greatly have influences on the electrical characteristic and the reliability (such as humidity resistance)of the SHA Devices which have been mounted on the board. It shall be confirmed that the characteristic and the reliability of the devices are not affected by the applied cleaning conditions.

5.8.2. When an ultrasonic cleaning is applied to the mounted SHA Devices on PC Boards.

Following conditions are recommended for preventing failures or damages of the devices due to the large vibration energy and the resonance caused by the ultrasonic waves.

- (1) Frequency 29MHz max
- (2) Radiated Power 20w/lithr max
- (3) Period 5minuets max

Part No. :	<b>1206SA240-030J</b>	Document No.	<b>AS-RD1206MA127-LF</b>	REV.	<b>C</b>
------------	-----------------------	--------------	--------------------------	------	----------

## 6. Packaging Specification

6.1 Carrier tape and transparent cover tape should be heat-sealed to carry the products, and the reel should be used to reel the carrier tape.

6.2 The adhesion of the heat-sealed cover tape shall be 40 +20/-15 grams.

6.3 Both the head and the end portion of the taping shall be empty for reel package and SMT auto-pickup machine. And a normal paper tape shall be connected in the head of taping for the operator to handle.

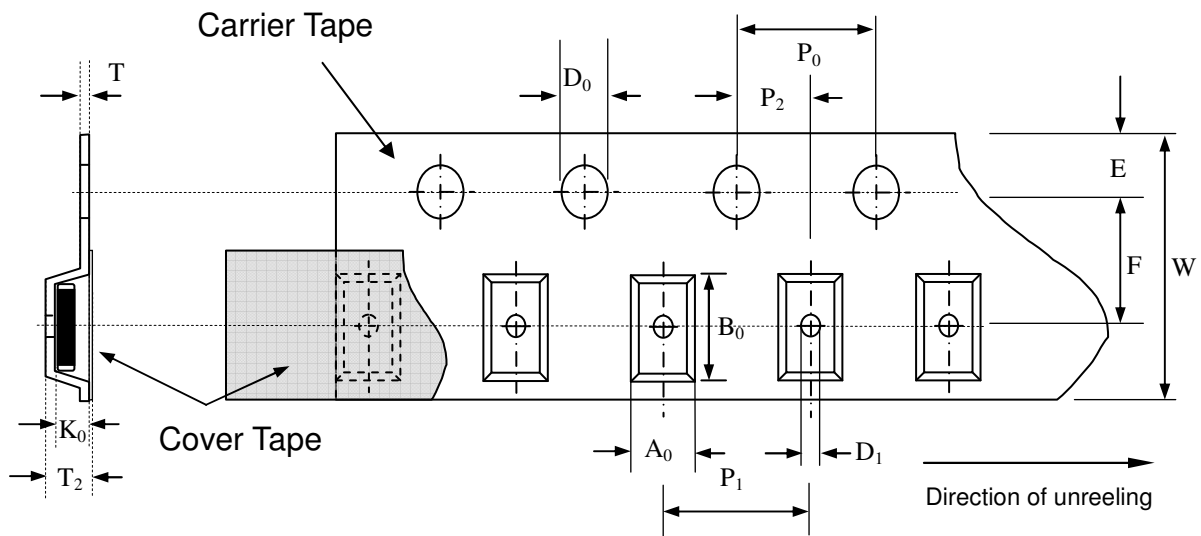

Symbol	A <sub>0</sub> ±0.10	B <sub>0</sub> ±0.10	K <sub>0</sub> ±0.10	T ±0.05	T <sub>2</sub> ±0.05	D <sub>0</sub> +0.10 -0.00	D <sub>1</sub> ±0.05	P <sub>1</sub> ±0.10	P <sub>2</sub> ±0.05	P <sub>0</sub> ±0.05	W ±0.20	E ±0.10	F ±0.05
1206	1.99	3.55	2.10	0.22	2.32	1.50	1.00	4.00	2.00	4.00	8.00	1.75	3.50

Part No. :	1206SA240-030J	Document No.	AS-RD1206MA127-LF	REV.	C
------------	----------------	--------------	-------------------	------	---

### 7.Reel Dimension

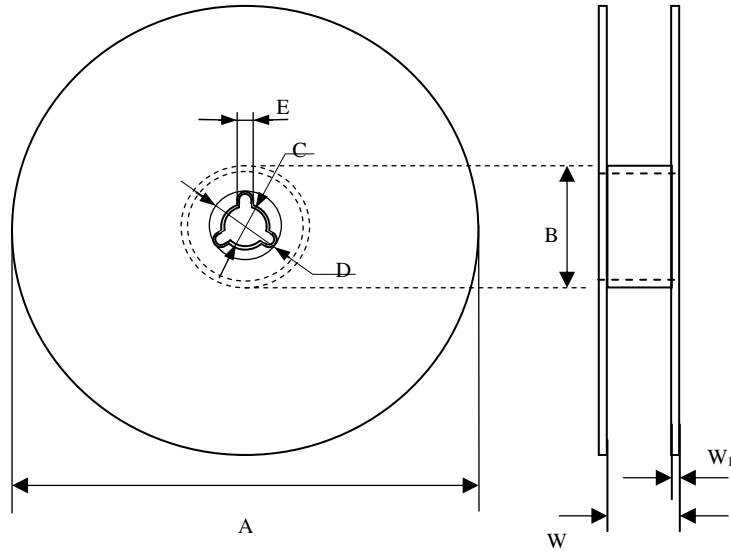

Symbol	A	B	C	D	E	W	W <sub>1</sub>
1206	178.0±1.0	60.0±0.5	13.0±0.2	21.0±0.2	2.0±0.5	9.0±0.50	1.5±0.15

### 8.Standard Packaging

Size	1206
Pcs	2000

Part No. :	1206SA240-030J	Document No.	AS-RD1206MA127-LF	REV.	C
------------	----------------	--------------	-------------------	------	---