



PART NO. 2220SA240-500J

1.1 Technology Data

	Symbol	Value	Unit
Maximum allowable continuous AC voltage at 50-60 Hz	V_{RMS}	14	V
Maximum allowable continuous DC voltage	V_{DC}	18	V
Breakdown voltage measured	V_V	24(±10%)	V
Maximum clamping voltage	V_{CLAMP} <	40	V
Maximum Peak Current	I_{Peak}	5000 (for +/- 1 time)	A
Jump Start Voltage (5min)	V_{JUMP}	24.5	V
Load Dump	W_{LD}	50 (for 10 times)	J

1.2 Reference Data

Typical capacitance value measured at 1K Hz	C	15000	pF
Response time	T_{rise} <	1	ns
Non-linear coefficient	α >	20	
Leakage current (Before Surge Test)	I_V <	10	uA
Leakage current (After Surge Test)	I_{VA} <	50	uA
Operation ambient temperature		-55~+125	°C
Storage temperature		-55~+150	°C

1.3 Other Data

Body		Nano Special Ceramic
End termination		Ag/Sn(1206~2220)
Packaging		Reel
Complies with Standard		IEC61000-4-5 ISO7637-2
Complies with RoHs Standard		Yes
Lead Content	<	1000 ppm
Marking		None

Notes :

- * 1 The breakdown voltage was measured at 1 mA current.
- * 2 The clamping voltage was measured at standard current, 2220(10A).
- * 3 The Peak Current was tested at 8/20 us waveform.
- * 4 Load Dump meet ISO7637-2 pulse 5.
- * 5 The leakage current was tested at working voltage, 12V.
- * 6 The capacitance value only for customer reference, it's not formal specification.
- * 7 The components shall be employed within 1 year, in the nitrogen condition.

Part No. :	2220SA240-500J	Document No.	AS-RD2220MA128-LF	REV.	B
------------	-----------------------	--------------	--------------------------	------	----------

1.4 Features of SHA Series

1. RoHS compliant
2. SMD type Body size 2220
3. Meet ISO7637-2 pulse 5
4. Bidirectional and symmetrical V/I characteristics
5. Large withstanding surge current capability : 5000A (@8/20)
6. Excellent low leakage current <math><10\mu\text{A}</math>
7. The jump start is 24.5V of 5min
8. Large Load Dump withstanding capability : 50J (10 times)
9. Operating temperature range : -55 ~ +125°C
10. Multi-Layers construction provides higher power dissipation

Equivalent Circuit

- ☆L Body Inductance
- ☆C Device Capacitance
- ☆VR Voltage Variable Resistor
- ☆R Insulation Resistor
- ☆Diode Voltage clamped
- ☆PTC For low leakage current

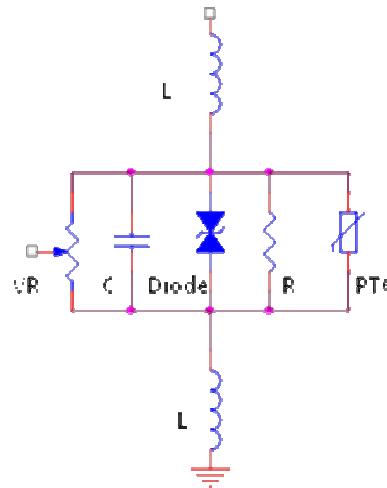

2.Size

Model	2220 Series
Length(L)	6.1 ±0.40mm
Width(W)	5.2 ±0.30mm
Thickness(T)	3.50 mm Max
Termination(a)	0.5+0.35/-0.1mm

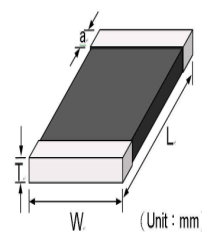

Part No. :	2220SA240-500J	Document No.	AS-RD2220MA128-LF	REV.	B
- 3 -					

3. Load Dump and Surge Wave Form

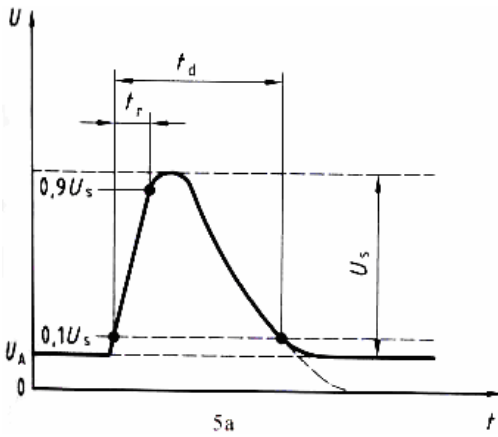

Load Dump Test waveform

ISO7637-2:2004 pulse 5a

Parameter	Value
Us	65V to 87V
Ri	0.5 Ω to 4 Ω
td	40ms to 400ms
tr	5ms to 10ms

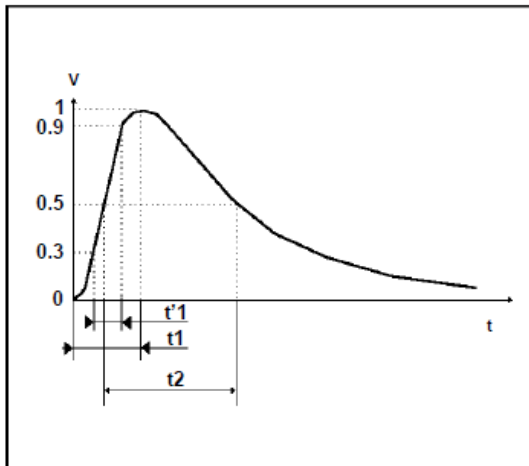

8/20µs waveform current

IEC61000-4-5 Standards

SEVERITY LEVEL	t1 (=1.67t'1)	t2
1	8 µs	20 µs

Part No. :	2220SA240-500J	Document No.	AS-RD2220MA128-LF	REV.	B
------------	-----------------------	--------------	--------------------------	------	----------



4. Environmental Reliability Test

Item	Requirement	Test condition
High Temperature Storage	1.Breakdown voltage change : within $\pm 10\%$ 2.No mechanical damage	1.Temperature : $150\pm 2^{\circ}\text{C}$ 2.Time : 1000 ± 2 hours 3.Test after placing in ambient temperature for 24 hours.
Low Temperature Storage	1.Breakdown voltage change : within $\pm 10\%$ 2.No mechanical damage	1.Temperature : $-40\pm 2^{\circ}\text{C}$ 2.Time : 1000 ± 2 hours 3.Test after placing in ambient temperature for 24 hours.
Temperature Cycle	1.Breakdown voltage change : within $\pm 10\%$ 2.No mechanical damage	1.Step 1 : $-40\pm 3^{\circ}\text{C}$; time : 30 ± 3 min 2.Step 2 : 25°C ; time : 1 hour 3.Step 3 : $-125\pm 3^{\circ}\text{C}$; time : 30 ± 3 min 4.Step 4 : 25°C ; time : 1 hour 5.Number of cycle : 5 times 6.Test after placing in ambient temperature for 24 hours.
High Temperature Load	1.Breakdown voltage change : within $\pm 10\%$ 2.No mechanical damage	1.Temperature : $125\pm 2^{\circ}\text{C}$ 2.Rated working voltage applied 3.Time : 1000 ± 2 hours 4.Test after placing in ambient temperature for 24 hours.
Damp Heat Load/ Humidity Load	1.Breakdown voltage change : within $\pm 10\%$ 2.No mechanical damage	1.Temperature : $40\pm 2^{\circ}\text{C}$ 2.Humidity : 90~95% RH 3.Rated working voltage applied 4.Time : 500 ± 2 hours 5.Test after placing in ambient temperature for 24 hours.

Part No. :	2220SA240-500J	Document No.	AS-RD2220MA128-LF	REV.	B
------------	-----------------------	--------------	--------------------------	------	----------

5. Soldering Recommendations

5.1 Recommended solder pad layout

(Unit : mm)

	A	B	C
2220	3.8~4.6	1.3~2.2	4.8~5.5

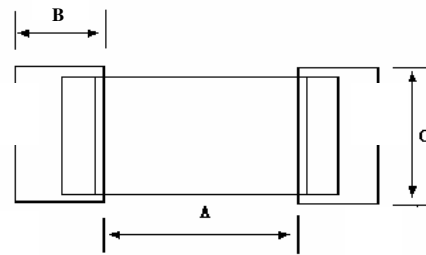

5.2 The SIR test of the solder paste shall be done (Based on JIS-Z-3284)

5.3 Steel plate and foot distance printing

Foot distance printing (mm)	Steel Plate thickness (mm)
> 0.65mm	0.18mm
0.65mm~0.5mm	0.15mm
0.50mm~0.40mm	0.12mm
<=0.40 mm	0.10mm

5.4 The IR reflow and temperature of Soldering for Pb Free

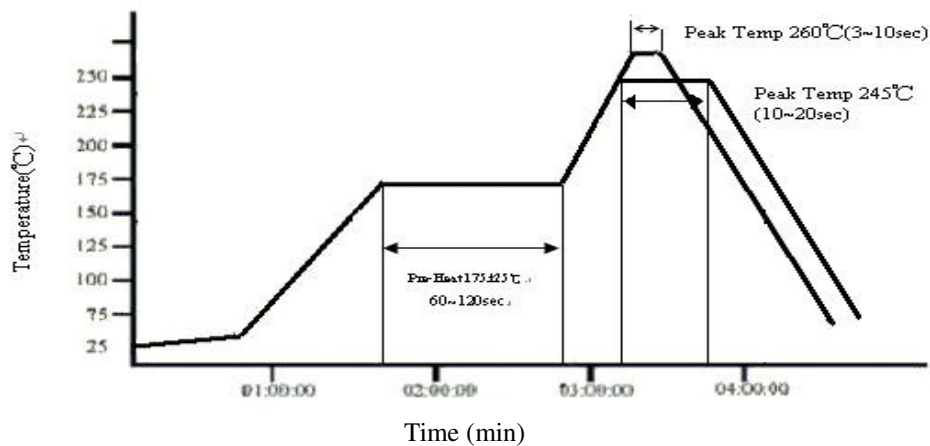

☆ IR reflow Pb Free Process suggestion profile

- (1) The solder recommend is Sn96.5/Ag 3.5 of 120 to 150 μ m
- (2) Ramp-up rate (217°C to Peak) + 3°C/second max
- (3) Temp. maintain at 175 +/-25°C 180 seconds max
- (4) Temp. maintain above 217 °C 60-150 seconds
- (5) Peak temperature range 245°C +20°C / -10 °C

Part No. :	2220SA240-500J	Document No.	AS-RD2220MA128-LF	REV.	B
- 6 -					



※Perform adequate test in advance as the reflow temperature profile will vary according to the conditions of the manufacturing process, and the specification of the reflow furnace.

5.5 Resistance to Soldering Heat-High Temperature Resistance: 260°C, 10sec and 3 times.

5.6 Hand Soldering

In hand soldering of the SHA Devices. Large temperature gradient between preheated the SHA Devices and the tip of soldering iron may cause electrical failures and mechanical damages such as crackings or breakings of the devices. The soldering shall be carefully controlled and carried out so that the temperature gradient is kept minimum with following recommended conditions for hand soldering.

5.6.1 Recommended Soldering Condition 1

- (1) Solder :
0.12~0.18mm Thread solder (Sn96.5:Ag3.5) with soldering flux in the core.
Rosin-based and non-activated flux is recommended.
- (2) Preheating
The SHA Devices shall be preheated so that Temperature Gradient between the devices and the tip of soldering iron is 150°C or below.
- (3) Soldering Iron
Rated Power of 20w max with 3mm soldering tip in diameter.
Temperature of soldering iron tip 380°C max, 3-5sec (The required amount of solder shall be melted in advance on the soldering tip.)
- (4) Cooling
After soldering. The SHA Devices shall be cooled gradually at room ambient temperature.

5.6.2 Recommended Soldering Condition 2 (Without preheating)

- (1) Solder iron tip shall not directly touch to ceramic dielectrics.
- (2) Solder iron tip shall be fully preheated before soldering while soldering iron tip to the external electrode of SHA Devices.

5.7 Recommended using IR Reflow Process. The Wave Soldering Process and Immersion Tin Process can't to be Adopted for this Product.

5.8 Post Soldering Cleaning

5.8.1 Residues of corrosive soldering fluxes on the PC board after cleaning may greatly have influences on the electrical characteristic and the reliability (such as humidity resistance)of the SHA Devices which have been mounted on the board. It shall be confirmed that the characteristic and the reliability of the devices are not affected by the applied cleaning conditions.

5.8.2. When an ultrasonic cleaning is applied to the mounted SHA Devices on PC Boards.

Following conditions are recommended for preventing failures or damages of the devices due to the large vibration energy and the resonance caused by the ultrasonic waves.

- (1) Frequency 29MHz max
- (2) Radiated Power 20w/lithr max
- (3) Period 5minuets max

Part No. :	2220SA240-500J	Document No.	AS-RD2220MA128-LF	REV.	B
------------	-----------------------	--------------	--------------------------	------	----------

6. Packaging Specification

6.1 Carrier tape and transparent cover tape should be heat-sealed to carry the products, and the reel should be used to reel the carrier tape.

6.2 The adhesion of the heat-sealed cover tape shall be 40 +20/-15 grams.

6.3 Both the head and the end portion of the taping shall be empty for reel package and SMT auto-pickup machine. And a normal paper tape shall be connected in the head of taping for the operator to handle.

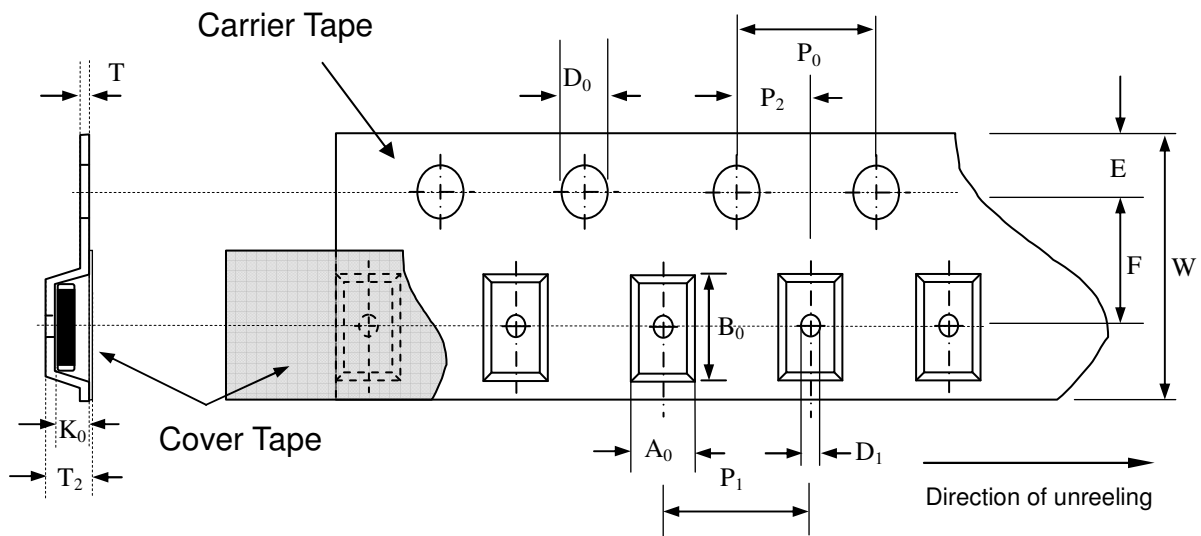

Symbol	A_0 ± 0.10	B_0 ± 0.10	K_0 ± 0.10	T ± 0.05	T_2 ± 0.05	D_0 $+0.10$ -0.00	D_1 ± 0.05	P_1 ± 0.10	P_2 ± 0.05	P_0 ± 0.05	W ± 0.20	E ± 0.10	F ± 0.05
2220	5.65	6.65	3.65	0.25	3.90	1.50	1.50	8.00	2.00	4.00	12.00	1.75	5.50

Part No. :	2220SA240-500J	Document No.	AS-RD2220MA128-LF	REV.	B
------------	----------------	--------------	-------------------	------	---

7.Reel Dimension

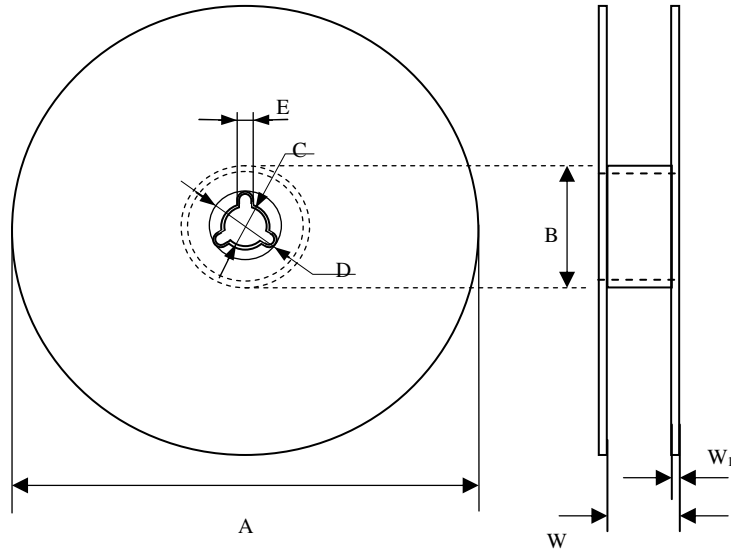

Symbol	A	B	C	D	E	W	W ₁
2220	178.0±1.0	60.2±0.5	13.0±0.5	21.0±0.2	2.5±0.5	13.6±0.2	1.5±0.15

8.Standard Packaging

Size	2220
Pcs	500

Part No. :	2220SA240-500J	Document No.	AS-RD2220MA128-LF	REV.	B
------------	----------------	--------------	-------------------	------	---